

D Projektgrundlagen  
D 5 Bushaltestellen

## D 5.26 Bewehrung Strassenablauf

Masstab 1:5 / 25 (Masse in cm)

### Grundriss

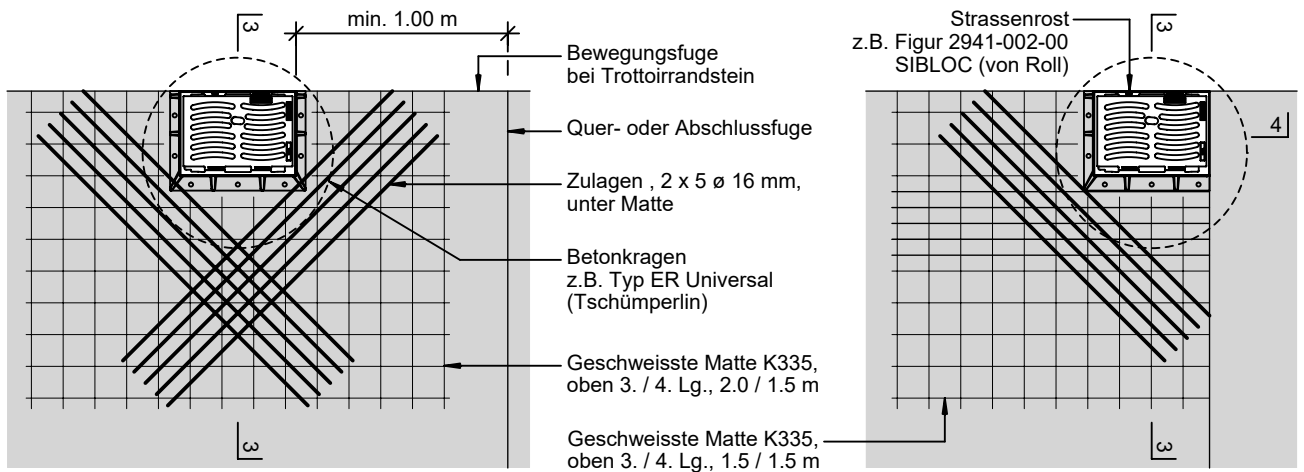

### Schnitt 3

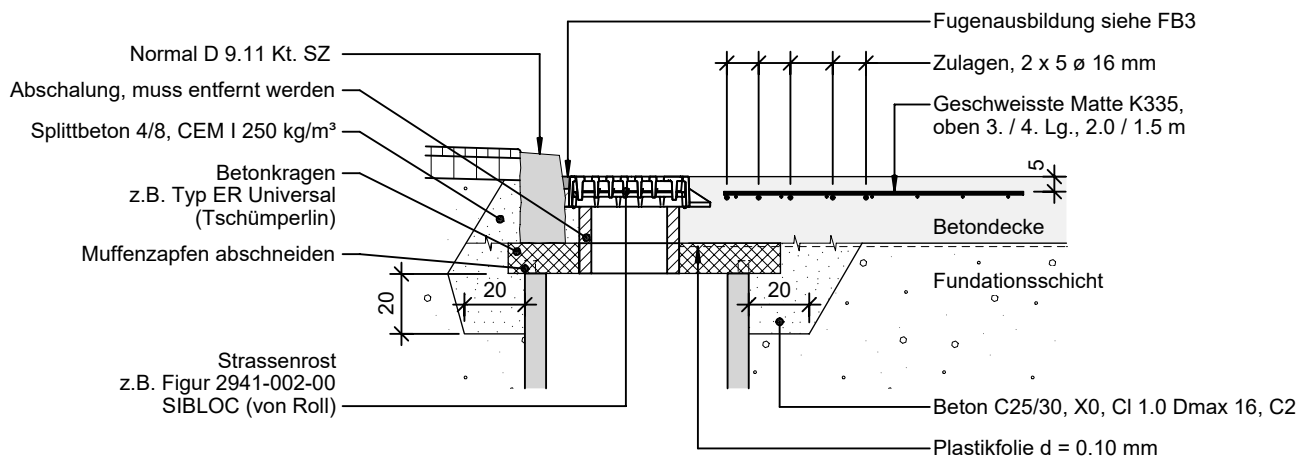

### Schnitt 4

